

VERSABEAM



Indoor luminaires in new "bowl shaped" form for 250W and 400W clear bulb high-pressure sodium and metal halide lamps. Especially useful for installation of 5-11 m height, in complicated assembly and machinery layouts and on sites with obstructions.

Body: die-cast aluminium ballast housing with electrocoat grey paint finish. It contains 230V 50Hz power supply unit with power factor correction, prepared for quick electronic and mechanic connection to the reflector containing also the lampholder.

Threaded hub on top allows quick and safe installation with matching hook (not included). Safety chain provisions available.

Optical assembly: basically a die-cast UV stabilised metacrylate refractor with prismatic finish for optimum light output. Hinged to a circular high purity aluminium reflector with ALGLAS coating (see page 144) and fastened to it through gasket by 4 stainless steel latches preventing fall. The lampholder fastened to the reflector, surrounded by a small prismatic parabolic refractor for the maximum optical performances. On the outside, the reflector is provided with positioning element for the quick connecting to the body. Built-in carbon filter guarantees the optics to remain clean for a long time.

Safety chain against fall is also available.

Lampholder: E40 porcelain.

Power supply: 230V 50Hz, with power factor correction, $\cos \phi \geq 0,9$. Maximum ambient temperature: 55°C.

Installation height: 5 - 11 m.

Installation: with die-cast aluminium hook and safety fixing bolts.

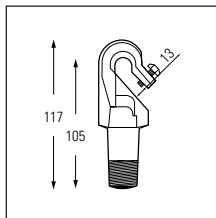
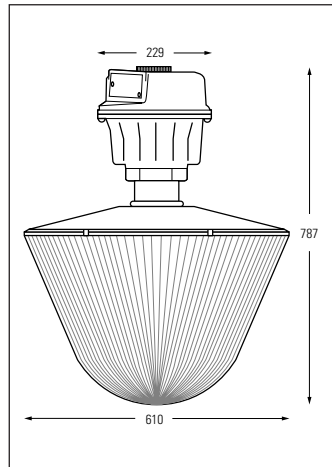

Type	Lamp	Tot. Absorbed Power (W)	Weight (kg)	Pack Qty.	Product Code
IP 52 gearbox		Class: I			
		230V 50Hz	IEC - CEI		
FGS25S	LU250/T/40	275	8,80	1	30771
FGS40S	LU400/T/40	436	9,90	1	30776
FGS25MBF	MVR250/U/40	275	8,80	1	30788
FGS40MBF	MVR400/U/40	430	8,80	1	30825

HPF = with power factor correction - Without lamp.

Type	Lamp	Tot. Absorbed Power (W)	Weight (kg)	Pack Qty.	Product Code
IP 54 reflector - diffuser					
VBDGEA	LU250/400/T/40	610	6,30	1	31337
VBDVEA	MVR250/U/40	610	6,30	1	31338
VBDAEA	MVR400/U/40	610	6,30	1	31339

Warning: VERSABEAM is not suitable for high-pressure mercury vapour lamps.

Type	Description	Weight (kg)	Pack Qty.	Product Code
Suspension hook				
HOOKM	With seal IP52	0,15	1	31232
HOOKMG	With seal IP54	0,16	1	31269

Accessories

Safety chain				
SFC3-B	For the body, of. 0,9 m length	0,25	1	31273
SFC-O	For the reflector	0,10	1	31277